



BLMD-8CTV39-B1P-TSM4 High Voltage Brushless DC Motor Driver

Product Datasheet

BLMD-8CTV39-B1P-TSM4 is a high voltage, three phase, trapezoidal wave and hall sensed Brushless DC Motor Driver (BLMD). This driver has two sub-types, AC type and DC type. AC type is suitable for 75-275VAC, 50/60Hz, one phase power supply. And DC type is suitable for 75-390VDC power supply. Three phase rated output current is 8ADC.

- Internal AC to DC Rectifier and Filter (Only for AC type)
- Three Phase IGBTs H-Bridge (15.625kHz PWM)
- Hall Sensor Electrical Phasing 120°/240°
- Reference Voltage for Hall Sensors--+5V
- Motor Over Temperature Protection--PTC
- Forward/Reverse Direction Control--F/R
- Speed Frequency Feedback--FG
- System Malfunction Fault Feedback--FLT
- Run Enable/Disable Control--En
- Dynamic Braking Control--BRK
- PWM Control--ADJ
- PWM Gradient Control--dt
- Motor Line Current Feedback--CFB
- Input Voltage Feedback--VFB
- Heat Sink Temperature Feedback--TFB
- Motor Running Direction Feedback--DIR
- Over Current Protection
- Over Voltage Lockout
- Under Voltage Lockout
- Heat Sink Over Temperature Protection

<u>8</u>	<u>C</u>	<u>T</u>	<u>V</u>	<u>39</u>	-	<u>B</u>	<u>1P</u>	-	<u>T</u>	<u>S</u>	<u>M4</u>
↓	↓	↓	↘	↘		↙	↙		↓	↓	↓
<u>Rated</u>	<u>Current</u>	<u>Temperature</u>	<u>Voltage</u>	<u>Max</u>		<u>Bootstrap</u>	<u>One Phase</u>		<u>Trapezoidal</u>	<u>S: Sensed</u>	<u>Sub-type</u>
<u>8ADC</u>	<u>Protection</u>	<u>Protection</u>	<u>Lockout</u>	<u>390VDC</u>			<u>Protection</u>		<u>Wave</u>	<u>SL: Sensorless</u>	

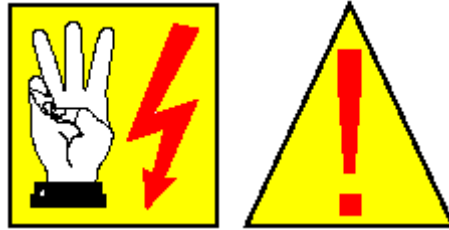

Please read Safety Warning below carefully before installing and operating this driver!

- **This product should be installed and serviced by a qualified technician, electrician, or electrical maintenance person familiar with its operation and the hazards involved.**
- **Proper installation, which includes wiring, mounting in proper enclosure, fusing, cooling, and grounding can reduce the chance of electrical shocks, fires, or explosion in this product or products used with this product, such as motors, coils, hall sensors and/or other circuits connected to it.**
- **Be sure to eliminate body static electricity when operation.**
- **To connect or disconnect any junction when power on is FORBIDDEN. J3 or J4 phase missing is FORBIDDEN.**
- **Do not touch the PCB board, and/or other circuits connected to it, when power on. Eye protection must be worn and insulated tools must be used when working under power.**
- **All output and input terminals are NOT ISOLATED from the incoming AC mains supply and may be at up to 400V with respect to earth, regardless of the input mains supply voltage applied. These terminals are live during connection. Do not attempt to access these terminals during this time.**



Absolute Maximum Ratings

(The Absolute Maximum Ratings are those values beyond which the safety of the driver cannot be guaranteed)

Parameter	Symbol	Value	Unit
Power Supply Voltage	V _{J1}	275 (rms)	VAC
		390 (max)	VDC
Three Phase Peak Output Current	I _A , I _B , I _C	19 (peak)	ADC
Min Permissible Inductance of Motor	L _{Motor} (line to line)	1	mH
Max Controllable Motor Speed	One Magnetic Pole-pair Rotor	50000	rpm
Hall Reference Voltage Output Current	I _{+5V}	20	mA
Hall, PTC, F/R, EN, BRK, ADJ, dt Inputs Voltage Range	V _{Ha} , V _{Hb} , V _{Hc} , V _{PTC} , V _{F/R} , V _{EN} , V _{BRK} , V _{ADJ} , V _{dt}	-0.5 to +5.5	V
FG, FLT, CFB, VFB, TFB, DIR Outputs Shortcut Current	I _{FG} , I _{FLT} , I _{CFB} , I _{VFB} , I _{TFB} , I _{DIR}	+25 (Shortcut to GND) -25 (Shortcut to +5V)	mA
Operating Ambient Temperature Range	T _a	-10 to +70	C
HIPOT	J1: N/L to Earth	2000VDC, 1s	

Electrical Characteristics

(J1=220VAC, 50Hz, T_a=20C, unless otherwise noted)

Parameter	Symbol	Min	Typical	Max	Unit
-----------	--------	-----	---------	-----	------

J1--Power Supply

AC 50/60Hz, 1 Phase	V _{AC}	75	110/220	275	VAC
	I _{AC}	-	10	-	AAC
DC	V _{DC}	75	155/310	390	VDC
	I _{DC}	-	8	-	ADC

J3--Three Phase Driver Output

A, B, C Driver Output	V _{ABC}	-	155/310	-	VDC
	I _{ABC}	-	8	-	ADC
PWM Frequency	f _{PWM}	-	15.625	-	kHz
PWM Resolution	ΔPWM	-	1/256	-	-

J4--+5V--Reference Voltage for Hall Sensors

Output Voltage	V _{+5V}	4.8	5.1	5.4	VDC
Output Current	I _{+5V}	-	-	20	mA

J4--Ha, Hb, Hc--Digital Inputs

High Threshold Volt	V _{IH}	3.5	-	5.5	V
Low Threshold Volt	V _{IL}	-0.5	-	1.5	V
High State Current	I _{IH}	-	-	3.2	mA
Low State Current	I _{IL}	-	-	4.5	mA



J5--PTC--Digital Input

High Threshold Volt	V _{IH}	3.5	-	5.5	V
Low Threshold Volt	V _{IL}	-0.5	-	1.5	V
High State Current	I _{IH}	-	-	1.5	mA
Low State Current	I _{IL}	-	-	5.5	mA

J2--FG, FLT, DIR--Digital Outputs

High State Volt	V _{OH}	4	-	-	V
Low State Volt	V _{OL}	-	-	0.7	V
Source Current	I _{OH}	-	-	1	mA
Sink Current	I _{OL}	-1	-	-	mA

J2--F/R--Digital Input

High Threshold Volt	V _{IH}	4.5	-	5.5	V
Low Threshold Volt	V _{IL}	-0.5	-	0.5	V
High State Current	I _{IH}	-	JFR@LOW	-1.8	mA
Low State Current	I _{IL}	-	JFR@HIGH	0.17	mA

J2--EN, BRK--Digital Inputs

High Threshold Volt	V _{IH}	3.5	-	5.5	V
Low Threshold Volt	V _{IL}	-0.5	-	1.5	V
High State Current	I _{IH}	-	-	0.08	mA
Low State Current	I _{IL}	-	-	0.25	mA

J2--ADJ--PWM Control Analog Input

0% / 100% PWM	V _{ADJ}	1.28	-	3.83	V
Input Current @3.83V	I _{IH}	-	-	-6.5	uA
Input Current @1.28V	I _{IL}	-20	-	-	uA
A/D Resolution	ΔV	-	1/256 (0.01V)	-	-

J2--dt--PWM Gradient Control Analog Input

0us / 355123200us	V _{dt}	1.28	-	3.83	V
Input Current @3.83V	I _{IH}	-1.2	-	-	mA
Input Current @1.28V	I _{IL}	-	-	1.2	mA
A/D Resolution	ΔV	-	1/256 (0.01V)	-	-

J2--CFB--Motor Line Current Feedback Analog Output

Output Volt Range	V _{CFB}	0	-	6	V
Coefficient	K _{CFB}	-	3.125A/1V	-	ADC/VDC



J2--VFB--Input Voltage Feedback Analog Output

Output Volt Range	V _{VFB}	0	-	5.5	V
Coefficient	K _{VFB}	-	100V/1V	-	VDC/VDC

J2--TFB--Heat Sink Temperature Feedback Analog Output

Output Volt Range	V _{TFB}	0	-	5.5	V
-------------------	------------------	---	---	-----	---

Over Current Protection

Lockout Current	I _A , I _B , I _C	-	19	-	ADC
Unlock Current	I _A , I _B , I _C	-	4	-	ADC

Over Voltage Lockout

Lockout Voltage	V _{BEMF}	-	400	-	VDC
Unlock Voltage	V _{BEMF}	-	395	-	VDC

Under Voltage Lockout

Lockout Voltage	V _{BEMF}	-	50	-	VDC
Unlock Voltage	V _{BEMF}	-	45	-	VDC

Heat Sink Over Temperature Protection

Lockout Temperature	T _s	-	85	-	C
Unlock Temperature	T _s	-	75	-	C



Junction Table

Junction	Pin	Type	Function
J1	To Earth	-	Earth Line
	L(+)	Power Supply	AC Live Line, DC Positive
	N(-)	Power Supply	AC Null line, DC Negative
J3	A	Driver Output	A Phase Line Driver
	B	Driver Output	B Phase Line Driver
	C	Driver Output	C Phase Line Driver
J4	GND	Signals GND	Hall Sensors GND
	Ha	Digital Input	A Hall Sensor, TTL Compatible
	Hb	Digital Input	B Hall Sensor, TTL Compatible
	Hc	Digital Input	C Hall Sensor, TTL Compatible
	+5V	Reference Output	Reference Voltage for Hall Sensors
J5	PTC	Digital Input	One Pin of PTC
	GND	Signals GND	Another Pin of PTC
J2	F/R	Digital Input	Forward/Reverse Direction Control, TTL Compatible
	FG	Digital Output	Speed Frequency Feedback, TTL Compatible
	FLT	Digital Output	System Malfunction Fault Feedback, TTL Compatible
	EN	Digital Input	Run Enable/Disenable Control, TTL Compatible
	BRK	Digital Input	Dynamic Braking Control, TTL Compatible
	DN	Voltage Divider	Potentiometer Down Pin
	ADJ	Analog Input	PWM Control (Open Loop Stepless Speed Control)
	UP	Voltage Divider	Potentiometer Up Pin
	dt	Analog Input	PWM Gradient Control
	GND	Signals GND	Signals GND
	CFB	Analog Output	Motor Line Current Feedback
	VFB	Analog Output	Input Voltage Feedback
	TFB	Analog Output	Heat Sink Temperature Feedback
	DIR	Digital Output	Motor Running Direction Feedback, TTL Compatible
	GND	Signals GND	Signals GND



Main Functions Description

J1--Power Supply:

This driver has two sub-types, AC type and DC type.

AC type is suitable for 75-275VAC, 50/60Hz, 1 Phase power supply. There is a build-in rectifier and filter AC to DC converter. Its maximum load capability is 10AAC. The FUSE is 10A.

DC type is suitable for 75-390VDC power supply. Its maximum load capability is 8ADC.

Because of the different structures of GND Lines, these two sub-types cannot be substituted for each other. Otherwise the GND Lines will be broken.

J3--A, B, C Three Phase Line Drivers:

The driver internal circuit is shown in right figure. Three phase, trapezoidal wave, H-Bridge could drive either Y or Delta winding motor. Please see the "Commutation Truth Table" for reference.

The use of 15.625kHz Pulse Width Modulating (PWM) at the three bottom IGBTs provides an energy efficient method of controlling the motor speed by varying the average voltage applied to each stator winding during the commutation sequence. PWM resolution is 1/256.

To connect or disconnect J3 when power on is FORBIDDEN! J3 phase missing is FORBIDDEN!

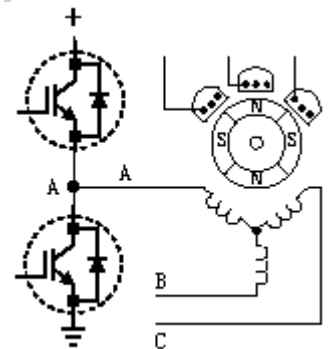

J4--+5V--Reference Voltage for Hall Sensors:

+5.1VDC reference power could output Max 20mA for hall sensors.

It is FORBIDDEN to supply any other loads!

J4--Ha, Hb, Hc--Hall Digital Inputs:

TTL compatible. The internal circuit is shown in right figure. Please see the "Commutation Truth Table" for reference.

The hall sensor electrical phasing must be 120°/240°. And Ha, Hb, Hc signals must be connected correctly according to A, B, C windings. Otherwise the driver and motor may be damaged!

To connect or disconnect J4 when power on is FORBIDDEN! J4 phase missing is FORBIDDEN!

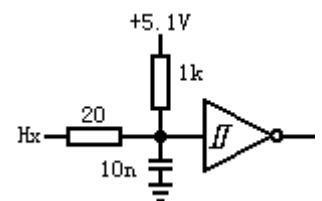

J5--PTC--Motor Over Temperature Protection Digital Input:

J5 connects to the internal temperature sensor of motor. TTL compatible. The internal circuit is shown in right figure. Please see the "Commutation Truth Table" for reference.

The circuit configuration parameter of J5 is only matching for MZ6 series PTC (Positive Temperature Coefficient Resistance). We could not guarantee J5 match other type of temperature sensor.

If PTC pin is high, FLT pin outputs low, FLT Led on, H-Bridge off (Z state). If PTC pin is low, driver auto-restart, and FLT pin outputs high, FLT Led off, H-Bridge on.

J5 could not be left floating. That means if it is left floating, PTC pin is always high, the driver is under protection for ever. So, please shortcut PTC to GND if not use.

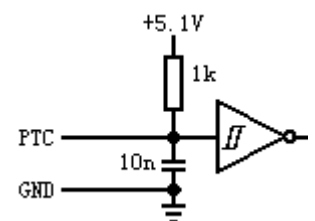



J2--F/R--Forward/Reverse Direction Control Digital Input:

TTL compatible. The internal circuit is shown in right figure. Please see the “Commutation Truth Table” for reference.

When F/R signal is high or float, the rotation direction of motor is forward. When F/R is low, it is reverse. When F/R is float, JFR switch could change the direction manually. The running direction also depends on the structure of BLDC motor and connection.

Suddenly reverse running when high speed is not recommended! Because the load, motor and driver maybe broken due to the pulse reversed acceleration, pulse current and heat. So, we suggest to use BRK function instead of F/R to brake the rotor and its load.

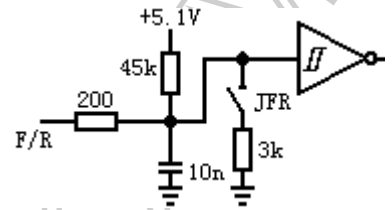

J2--FG--Speed Frequency Feedback Digital Output:

TTL compatible. The internal circuit is shown in right figure. Its frequency is linear to the motor speed. Pulse duty cycle is about 50%. The output waveforms are shown in left figure.



FG (Hz) = Speed (rpm) * n * 3 / 60. n means the number of magnetic pole-pairs (NOT POLES) of the rotor, n=1, 2, 3, 4.....

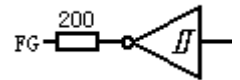

J2--FLT--System Malfunction Fault Feedback Digital Output:

TTL compatible. The internal circuit is shown in right figure. Please see the “Commutation Truth Table” for reference.

A logic high means the motor works normally. A logic low means there are something wrong and causes the FLT Led on and H-Bridge off (Z state).

There is a 1.2k resistance between FLT pin and GND, to provide logic low when power off.

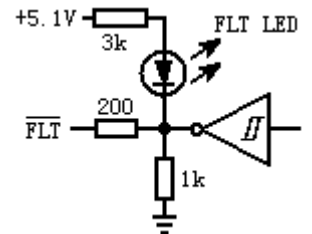

J2--En--Run Enable/Disenable Control Digital Input:

TTL compatible. The internal circuit is shown in right figure. Please see the “Commutation Truth Table” for reference.

A logic high or float causes motor works normally, while a low causes H-Bridge off (Z state) and motor to coast.

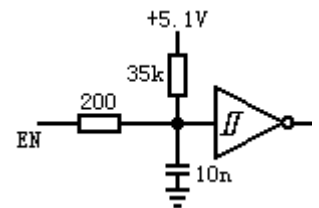

J2--BRK--Dynamic Braking Control Digital Input:

Please see chapter “How to Use BRK Function” for details.

J2--ADJ--PWM Control Analog Input:

Open loop stepless speed control. Analog signal. The internal circuit is shown in right figure.

An A/D converts the voltage of ADJ pin to a byte (0x00 to 0xFF). Software assigns this byte value to PWM according to dt algorithm. The Pulse Width Modulating at the three bottom IGBTs controls the motor speed by varying the average voltage applied to each stator winding.

A/D resolution is 1/256 (0.01V). The functional relation is piecewise function. Its expression is:

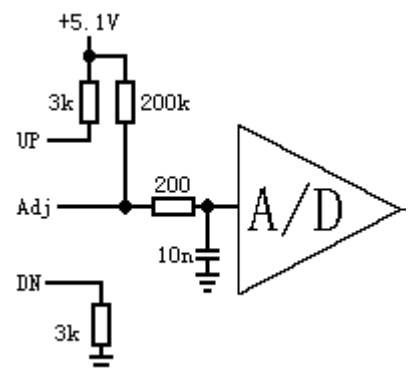



1. PWM=0x00, PWM%=0%, ($U_{ADJ} < 1.28V$);
2. PWM=($U_{ADJ}-1.28$)*100, PWM%=($(U_{ADJ}-1.28)*100/255$)*100%, ($1.28V \leq U_{ADJ} \leq 3.83V$);
3. PWM=0xFF, PWM%=100%, ($3.83V < U_{ADJ}$).

There are three ways to control speed:

First, connect the top foot and bottom foot of a 10kOhm potentiometer to the UP pin and DN pin of J2 separately. And connect the middle foot of the potentiometer to ADJ pin. 10kOhm must be used, other value is not matching. Please see the “Application Circuit Examples” for reference.

Second, using an operational amplifier (or D/A). Connect the output of operational amplifier (or D/A) directly to ADJ pin. Leave UP pin and DN pin floating.

Third, connect a filtered Pulse Width Modulation signal to ADJ pin. Leave UP pin and DN pin floating. There must be an external RC filter. $RC > 640\mu s$ and $f > 15kHz$ are recommended.

J2--dt--PWM Gradient Control Analog Input:

Analog signal. The internal circuit is shown in right figure.

ADJ controls the value of PWM, and dt controls the gradient of PWM. The physical significance of dt is the time constant of PID algorithm.

The software uses three steps to convert the analog voltage to a time constant.

First step: An A/D converts the voltage of dt pin to a byte (0x00 to 0xFF). A/D resolution is 1/256 (0.01V). The functional relation is piecewise function, the same as ADJ. Its expression is:

1. $n=0x00$, ($U_{dt} < 1.28V$);
2. $n=(U_{dt}-1.28)*100$, ($1.28V \leq U_{dt} \leq 3.83V$);
3. $n=0xFF$, ($3.83V < U_{dt}$).

Second step: In order to extend control range, software does a square, $N=n*n$. N is a word (two bytes). N could only be 0, 1, 4, 9,.....65025.

The last step: $dt=N*16\mu s$, the unit is us. It is just the time constant.

Let's have some samples. As shown in right figure. $tga=dPWM/dt=1/(N*16)$, the unit is 1/us.

1. If $n=0$, then $N=0$, then $dt=0\mu s$, $dPWM/dt=tga=infinity$. So the software assigns ADJ value to PWM as fast as possible, not any time constant.

2. If $n=1$, then $N=1$, then $dt=1*16=16\mu s$. That means, if now ADJ changes, software would not assigns ADJ value to PWM immediately. It will do $PWM=PWM+1$ (or $PWM-1$) every 16us. So PWM line slopes up or down gradually, $tga=dPWM/dt=1/16$ (1/us). Let's suppose: Now ADJ suddenly steps up from 1.28V to 3.83V, then PWM will start from 0x00, and $PWM++$ every 16us. So after 4080us (255 times of 16us), PWM slopes up to 0xFF (PWM=100%).

3. Because of square algorithm, N could not be 2 or 3.

4. If $n=2$, then $N=4$, then $dt=4*16=64\mu s$. Software would do $PWM=PWM+1$ (or $PWM-1$) every 64us. Let's suppose: Now ADJ suddenly steps up from 1.28V to 3.83V, then PWM will start from 0x00, and $PWM++$ every 64us. So after 16320us (255 times of 64us), PWM slopes up to 0xFF (PWM=100%).

5. And so on, $N=9, 16, \dots, 65025$.

6. The Max time constant: $n=255$, $N=n*n=65025$, $dt=N*16=65025*16=1040400\mu s$. Let's suppose: Now ADJ suddenly steps up from 1.28V to 3.83V, then PWM will start from 0x00, and $PWM++$ every 1040400us. So after

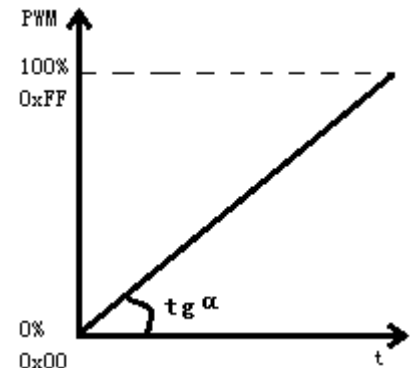
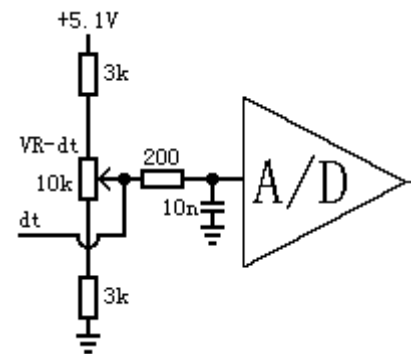



265302000us=4min25s (255 times of 1040400us), PWM slopes up to 0xFF (PWM=100%).

There are three ways to control speed:

First, adjust the VR potentiometer according to the arrow instructions on board "SLOW-FAST".

Second, using an operational amplifier (or D/A). Connect the output of operational amplifier (or D/A) directly to dt pin. Please see the "Application Circuit Examples" for reference.

Third, connect a filtered Pulse Width Modulation signal directly to dt pin. There must be an external RC filter. $RC > 640\mu s$ and $f > 15kHz$ are recommended.

J2--CFB--Motor Line Current Feedback Analog Output:

Analog signal. The internal circuit is shown in right figure.

This signal feeds back the line current of three phase, its unit is DC Ampere. It is linear. Please see the "Electrical Characteristics Table" for its Coefficient.

The formula of motor line current is: $I_{LINE} = V_{CFB} * 3.125$. The unit is ADC.

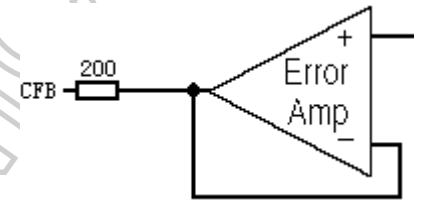

J2--VFB--Input Voltage Feedback Analog Output:

Analog signal. The internal circuit is shown in right figure.

This signal feeds back the rectified and filtered DC voltage (the voltage of the filter capacitor, namely the voltage of JX-BEMF pin). Its unit is DC Voltage. It is linear. Please see the "Electrical Characteristics Table" for its Coefficient.

The formula of motor voltage is: $V_{BEMF} = V_{VFB} * 100$. The unit is VDC.

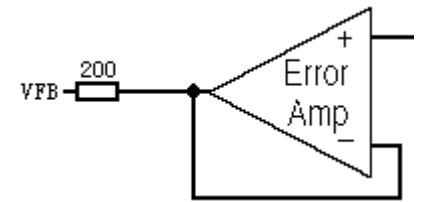

J2--TFB--Heat Sink Temperature Feedback Analog Output:

Analog signal. The internal circuit is shown in right figure.

This signal feeds back the temperature of the heat sink. It is non-linear due to the NTC. Please check below table for details.

Approximate linear formula: $T_s (C) = 85 - 31.25 * (3.69 - V_{TFB})$. This formula is precise enough in temperature range from 70 to 85C, but not precise enough in low temperature range.

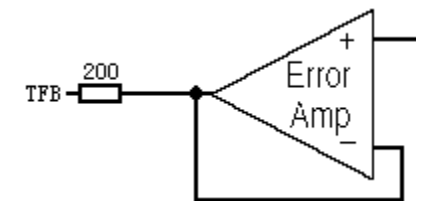

Heat Sink Temperature	T_s	50	60	70	75	80	85	C
Output Voltage	V_{TFB}	2.29	2.75	3.17	3.37	3.55	3.69	V

J2--DIR--Motor Running Direction Feedback Digital Output:

TTL compatible. The internal circuit is shown in right figure.

Motor only has two running directions, clockwise or counterclockwise. DIR outputs 0 or 1 to

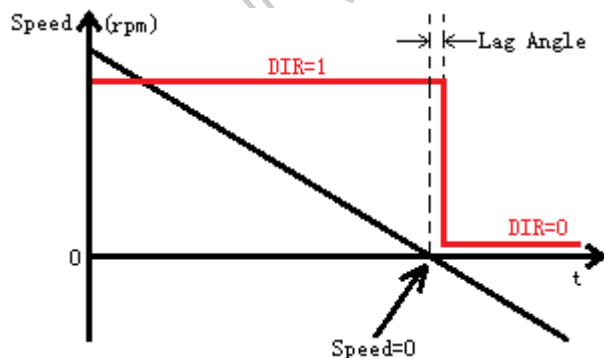

feedback the two directions separately. Whether 0=clockwise or 1=clockwise, depends on the structure of BLDC motor and should be determined by experiment.

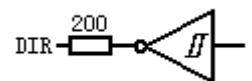

Shown in left figure. Theoretically, DIR reverses its output at the zero-crossing point of speed. That means, if suppose, on the left of zero-crossing point, motor runs clockwise and DIR=1; then on the right of zero-crossing point, it must be counterclockwise and DIR=0.



Encoder.

DIR reverses at just the point of the first Encoder signal behind the zero-crossing point. The max electrical lag angle is: $\theta_e < 60^\circ$. The max mechanical lag angle (shaft angle) is: $\theta_m = \theta_e / n$, n means the number of magnetic pole-pairs (NOT POLES) of the rotor, n=1, 2, 3, 4.....

Over Current Protection:

An over current protection circuit is inside this driver in order to limit the current of J3 H-Bridge. Please see the “Electrical Characteristics Table” for reference.

When current meets the upper limit, over current protection is active, and FLT pin outputs low, FLT Led on, H-Bridge off (Z state). When current returns to normal, driver auto-restart, and FLT pin outputs high, FLT Led off, H-Bridge on. Please see the “Commutation Truth Table” for reference.

Normally, the frequency of over current protection would be several hundred Hz to several kHz. And the motor winding will make a noise of the same frequency.

Over Voltage Lockout:

An over voltage lockout has been incorporated. Please see the “Electrical Characteristics Table” for reference.

When the rectified and filtered DC voltage goes up to trigger this function, FLT pin outputs low, FLT Led on, H-Bridge off (Z state). When voltage returns to normal, driver auto-restart, and FLT pin outputs high, FLT Led off, H-Bridge on. Please see the “Commutation Truth Table” for reference.

Please note: Over Voltage Lockout function perhaps does not have any capability to eliminate the root cause of voltage rising. So, even if lockout, the supply power voltage maybe still go up, the driver maybe still in danger.

Under Voltage Lockout:

An under voltage lockout has been incorporated to prevent damage to the IC and the H-Bridge. Please see the “Electrical Characteristics Table” for reference.

When the rectified and filtered DC voltage goes down to trigger this function, FLT pin outputs low, FLT Led on, H-Bridge off (Z state). When voltage returns to normal, driver does not restart immediately, it will wait for 1.5s, then auto-restart, and FLT pin outputs high, FLT Led off, H-Bridge on.

Similarly, when power supply turn on, the driver will wait for 1.5s first, then start. Please see the “Commutation Truth Table” for reference.

Heat Sink Over Temperature Protection:

A heat sink over temperature protection is inside the driver. Please see the “Electrical Characteristics Table” for reference.

85C sink temperature causes over temperature protection active, FLT pin outputs low, FLT Led on, H-Bridge off (Z state). When sink temperature drops down below 75C, driver auto-restart, and FLT pin outputs high, FLT Led off, H-Bridge on. Please see the “Commutation Truth Table” for reference.

Electrical Earthing:

J1-Earth pin is earth terminal, it directly connects to the Heat Sink. This pin is insulated from the rest of all circuits. Please see the “Absolute Maximum Ratings” for reference.



Commutation Truth Table

Hall Inputs			Control Inputs			PTC OT	OC	OV	UV	Sink OT	H-Bridge Driver			FLT pin	FLT LED
Ha	Hb	Hc	F/R	EN	BRK						A	B	C		
X	X	X	X	X	X	Any One Active					Z	Z	Z	0	ON
1	1	1	X	X	1	All Inactive					Z	Z	Z	0	ON
0	0	0	X	X	1						Z	Z	Z	0	ON
1	1	1	X	X	0						0	0	0	0	ON
0	0	0	X	X	0						0	0	0	0	ON
Six Valid Combinations (Figure Below)			X	0	X						Z	Z	Z	1	OFF
			X	1	0						0	0	0	1	OFF
			1/0	1	1	Normal Commutation (Figure Below)			1	OFF					

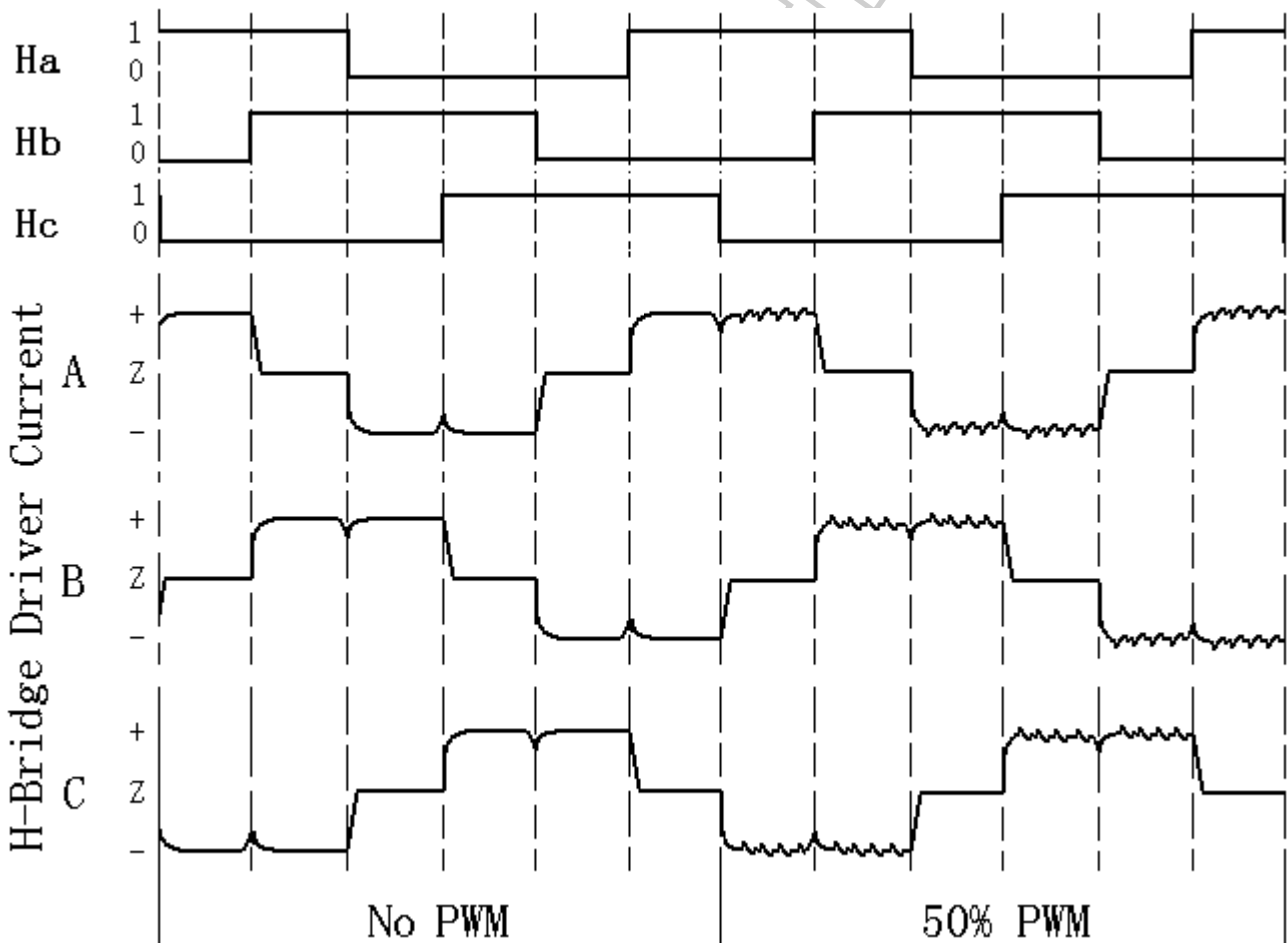

Normal Commutation Waveforms, F/R=1

Note: "1"=High, "0"=Low, "X"=Don't care, "Z"=High impedance, "+"= Positive current, "-"=Negative current



How to Use BRK Function

Default Setting

The default setting of BRK function is invalid. Please read the following instructions carefully before using this function!

About the Danger and Complexity of Brake Function

The danger and complexity are due to the Over Current Protection, the load and the external control circuit.

For the Over Current Protection: When using BRK function, the Over Current Protection is disabled. Inappropriate operation and control will cause the driver broken!

For the load: Please fix the motor and the load carefully before using this function. Otherwise the load maybe broken by the brake force and people maybe injured!

For the external control circuit: There must be an external circuit, accurate control software and a lot of experiments to verify the reliability of all the system, otherwise the driver and/or the motor and/or the external circuit maybe broken!

Simple Theory of Brake Function

Brushless DC Motor is not only a motor, but also a generator. As well, Brushless DC Motor Driver is not only a driver, but also a rectifier. Brake function is just using motor as a generator, to convert kinetic energy to three phase electric energy, and then rectify AC to DC, output DC electric energy to JX, and use up or store up electric energy.

There are two key items: First is the external circuit to use up or store up electric energy. Second is control logic.

External Circuit (This example only for reference)

Having an external circuit to use up or store up electric energy is very important. Generator continually converts kinetic energy to electric energy. If electric energy could not be used up as quickly as possible, the voltage of JX (BEMF pin) would keep on rising until trigger the Over Voltage Lockout. It is just the reason why the driver has the Over Voltage Lockout function.

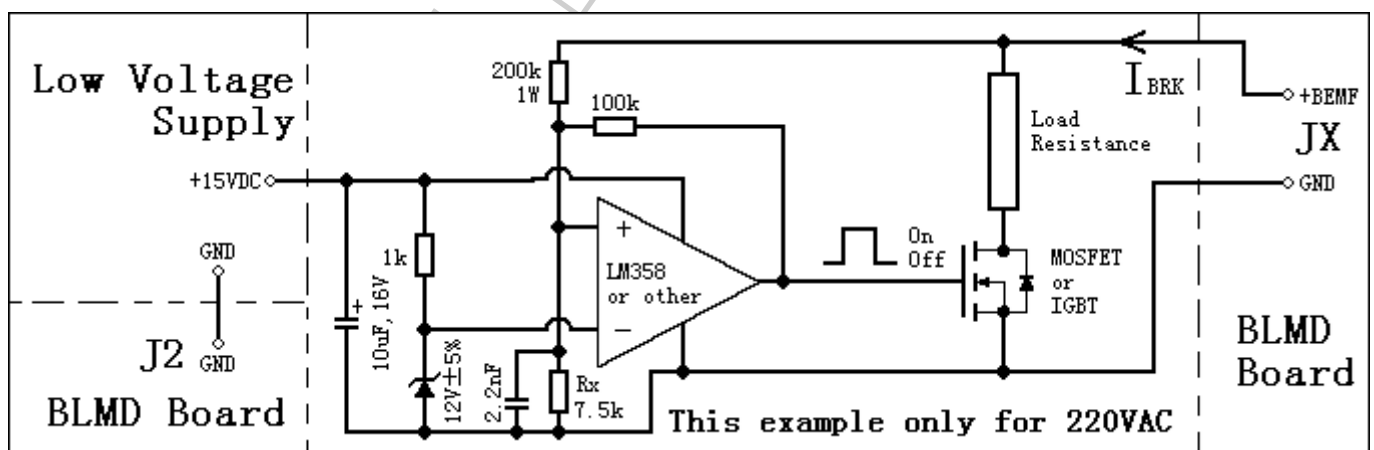

Customers must make an external circuit themselves, this circuit is not on our board.

For example, construct an external circuit as shown in above figure, including a comparator, a IGBTs (or IGBT), and a Load Resistance. This circuit could use up the electric energy automatically. When braking, kinetic energy converts to electric energy. The voltage of JX-BEMF pin rises up. The comparator turns on the IGBTs. Load Resistance converts electric energy to thermal energy. BEMF voltage drops down. The comparator turns off the IGBTs.

The power supply of above example is 220VAC. The comparator will turn on the IGBTs at BEMF=360VDC (on level), and turn off at BEMF=340VDC (off level). To increase/decrease the value of Rx will decrease/increase both the



on/off level.

Please note: Do not set the off level too low. It must be much higher than 310VDC, because 310VDC is the normal power supply voltage. Likewise, do not set the on level too high, it must be lower than 400VDC, because it is the level of Over Voltage Lockout. Please see the “Electrical Characteristics Table” for reference.

Choosing a proper Load Resistance is very important. Please see the “Absolute Maximum Ratings” for reference. The Rated Output Current is 8ADC. So the min value of Load Resistance is $360\text{VDC}/8\text{ADC}=45\text{ Ohm}$. If the value of Load Resistance is too low, the IBRK will be too high, and the driver will be broken.

Higher value of Load Resistance causes lower IBRK, and longer time duration of braking, and more frequent Over Voltage Lockout, vice versa. The dissipation power of Load Resistance should be carefully chosen according to the braking power and temperature, normally several hundred Watts or more.

If power supply is 110VAC, please set the comparator on level at $\text{BEMF}=220\text{VDC}$, and off level at $\text{BEMF}=200\text{VDC}$. Do not set the off level too low. It must be much higher than 155VDC, because 155VDC is the normal supply voltage.

Control Logic:

BRK signal is TTL compatible. The internal circuit is shown in right figure. Please see the “Commutation Truth Table” for reference.

A logic high or float allows motor running normally (motor mode), while a low causes motor to brake (generator mode).

In generator mode, ADJ and dt work in the same way as in motor mode. That means generator power is also determined by PWM and its gradient on H-Bridge.

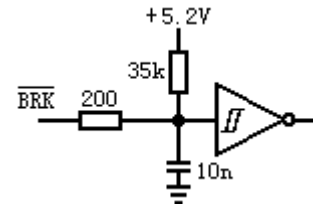

Warning again: When using BRK function, the Over Current Protection is disabled. That means the drive could not limit the braking current automatically. So proper input of ADJ and dt is the only way to control the generator power and braking current.

In consideration of prudent principle, during the experiment, we suggest: PWM duty cycle (ADJ) from low to high, PWM gradient (dt) from slow to fast, and the value of Load Resistance from high to low.

A sample of braking experiment:

Now let's use nature language to describe a braking software.

Before start, please be sure the external circuit is settled, motor and its loads are fixed properly. The purpose of this experiment is to program a software to brake a running motor.

First, let's suppose the initial states of the driver: EN=1 system on, BRK=1 motor mode, PWM=100% full speed running. There are four key points in the following software, please pay special attention:

```
Line1: EN=0; /*Turn off the driver.*/
```

```
Line2: dt=0; ADJ=0; /*This is the first key point: Although now EN=0 H-Bridge off, PWM is still 0xFF (100%). The changing of EN has no effect on PWM value. If now we let BRK=0, the motor will brake under 100% PWM, it is too hard and dangerous. So we first let dt=0 and ADJ=0. That means we hope PWM decrease to 0 as quickly as possible.*/
```

```
Line3: __delay_cycles(Client Delay+128us);
```

```
/*This is the second key point: Why use delay, there are two reasons. First, client system has time delay. For example, RC filter, transmission delay and so on. Client must guarantee enough delay time to decrease the voltage of dt pin and ADJ pin blow 1.28V. Second, A/D converter samples both the value of dt and ADJ every 64us. So delay 128us could guarantee PWM change to 0x00 (0%).*/
```

```
Line4: BRK=0; /*Change to generator mode.*/
```



Line5: dt=2.49V; /*This is the third key point: $n=(2.49V-1.28V)*100=121$, $N=n*n=121*121=14641$, that means the time constant is $14641*16\mu s*255$ about 60s (PWM from 0% to 100%). It is only a sample. We only want to express the prudent principle: from low to high, from slow to fast. For first time experiment, dt value should be assigned enough slow than needed.*/

Line6: __delay_cycles(Client Delay+128us); /*This is the fourth key point: We emphasize here, change dt first, and delay to guarantee, then change ADJ. If on the contrary, the result is not correct.*/

Line7: EN=1; /*Turn on the driver. Now, ADJ and PWM are all 0.*/

Line8: ADJ=5V; /*The experiment target is change PWM from 0% to 100%.*/

.....

/*Now PWM is increasing gradually. And motor is decelerating.*/

.....

/*Now motor stops.*/

Line9: EN=0; /*Round off work.*/

Line10: dt=0; ADJ=0;

Line11: __delay_cycles(128us+Client Delay);

For first time experiment, deceleration time maybe too long. Let's improve it gradually.

The purpose of following improvements is to increase the deceleration, reduce the time. We could change two items: First is dt, second is Load Resistance. Please note: Change these two items GRADUALLY.

Step1: Decrease dt to increase the generator power.

Step2: The consequence of Step1 is that Over Voltage Lockout becomes more and more frequently. So to decrease the value of Load Resistance, in order to increase the braking current.

Step3: The consequence of Step2 is that Load Resistance becomes hotter and hotter. So to increase the dissipation power of Load Resistance.

Please repeat above improvements until achieve your purpose.

Please note: The braking power could not be infinitely great. For the above sample, the max voltage is 360VDC, the max permissible current is 8ADC, the min permissible Load Resistance is 45 Ohm. So the max braking power is $360*8=2880W$. That means the deceleration could not be infinitely great, and also, the braking time could not be infinitely short.

The Final Step:

Please find out the JBRK junction, shown in right photo. And welded short cut on the PCB board. The brake function is valid.



Driver Dimension and Connection Diagram (Unit: mm)

The driver dimension is 156 (L) * 92 (W) * 75 (H). The approximate weight of the driver is 500g (including intrinsic heat sink).

The radiator can be custom-made according to the output power, heating and cooling condition of the application.

If the temperature of the sink is always higher than 85C, cooling fan must be installed. Otherwise the driver would be over temperature lockout.

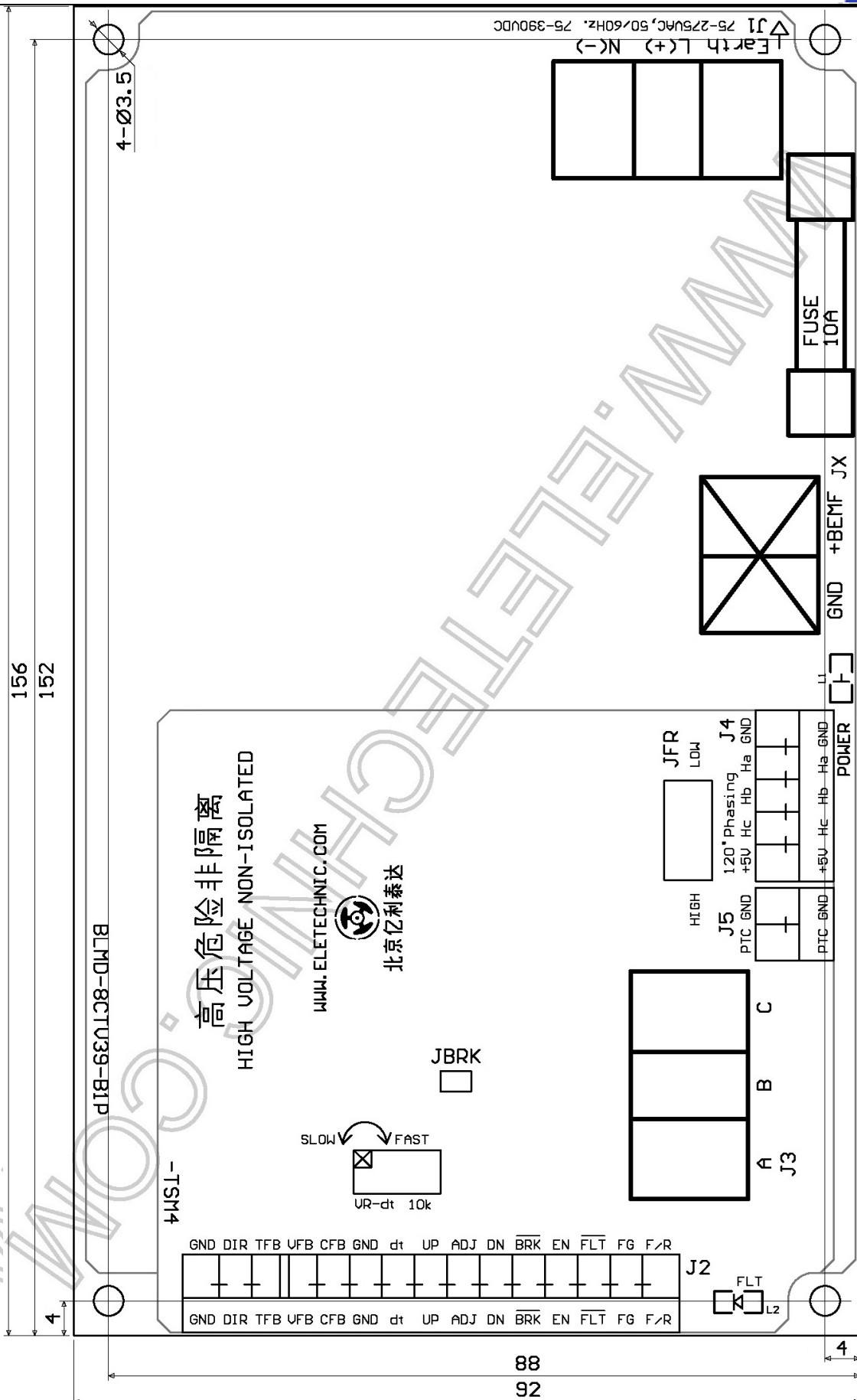



Application Circuit Examples

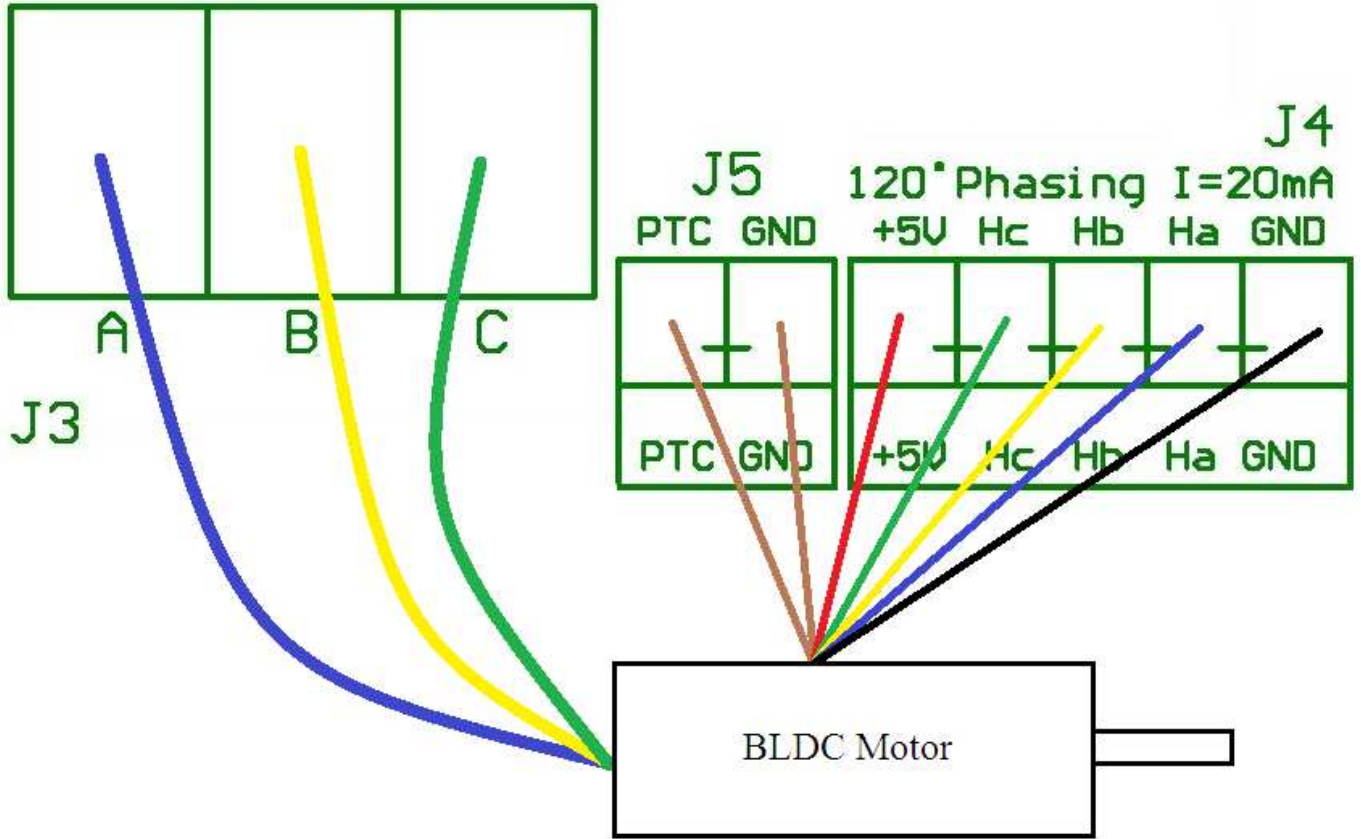

The Connection of BLDC Motor

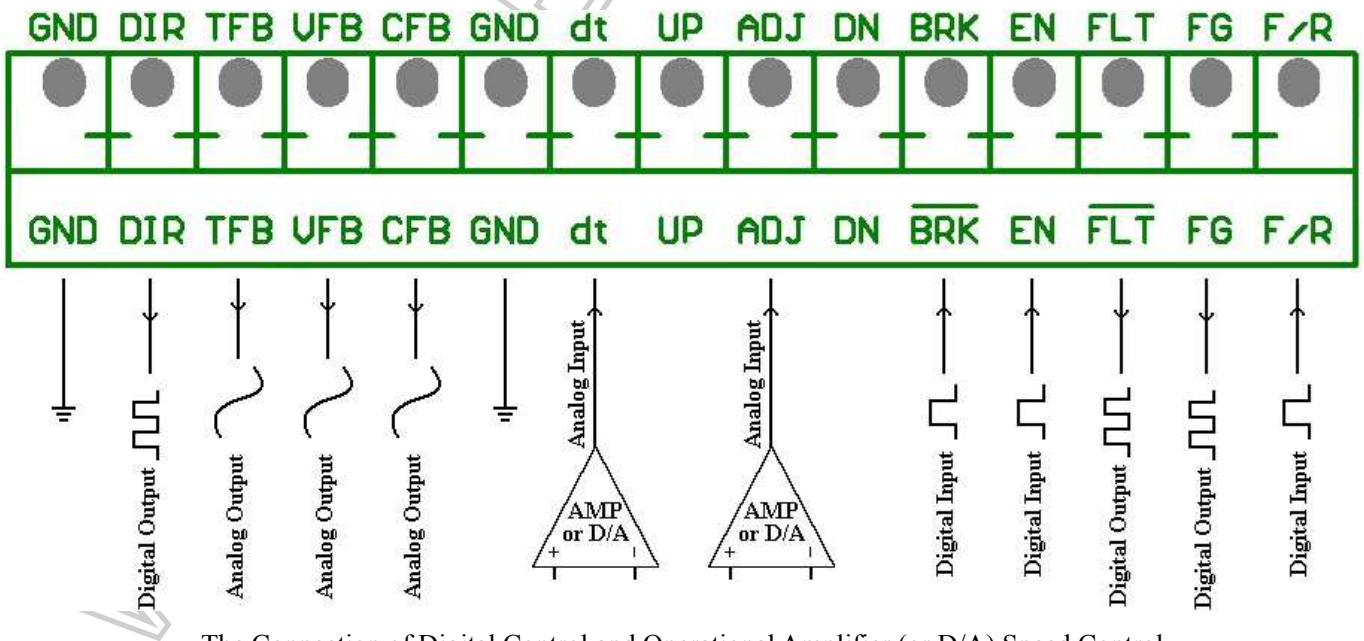

The Connection of Digital Control and Operational Amplifier (or D/A) Speed Control

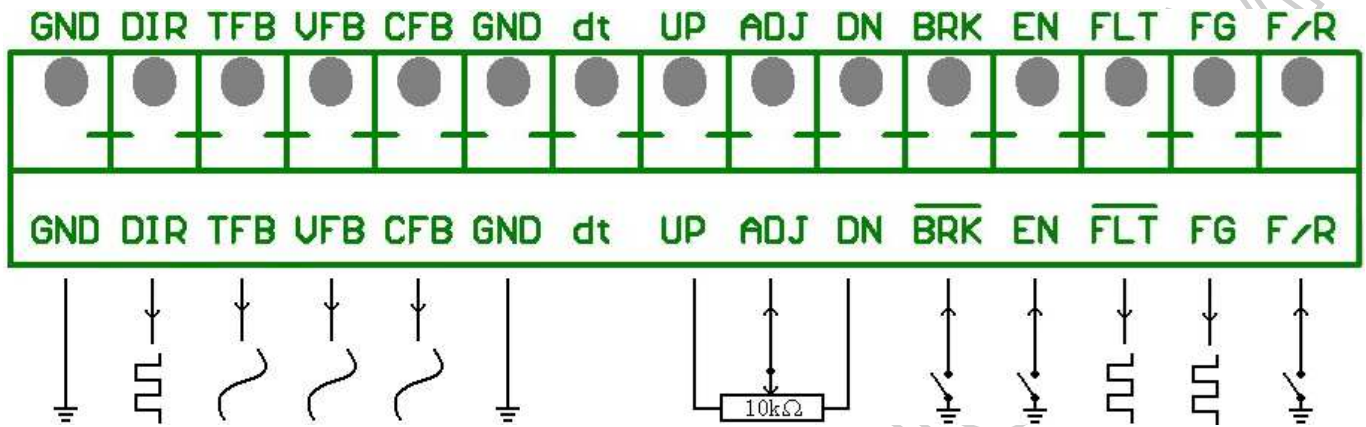

The Connection of Mechanical Switches and Potentiometer Speed Control



is registered trademark of Beijing Eletechnic Ltd. Eletechnic reserves the right to make changes without further notice to any products herein. Eletechnic makes no warranty, representation or guarantee regarding the suitability of its products for any particular purpose, nor does Eletechnic assume any liability arising out of the application or use of any product or circuit, and specifically disclaims any and all liability, including without limitation consequential or incidental damages. All parameters which may be provided in Eletechnic data sheets and/or specifications can and do vary in different applications and actual performance may vary over time. All operating parameters must be validated for each customer application by customer's technical experts. Eletechnic does not convey any license under its patent rights nor the rights of others. Eletechnic products are not designed, intended, or authorized for use as components in systems intended for surgical implant into the body, or other applications intended to support or sustain life, or for any other application in which the failure of the Eletechnic product could create a situation where personal injury or death may occur. Should Buyer purchase or use Eletechnic products for any such unintended or unauthorized application, Buyer shall indemnify and hold Eletechnic and its officers, employees, subsidiaries, affiliates, and distributors harmless against all claims, costs, damages, and expenses, and reasonable attorney fees arising out of, directly or indirectly, any claim of personal injury or death associated with such unintended or unauthorized use, even if such claim alleges that Eletechnic was negligent regarding the design or manufacture of the part.

Beijing Eletechnic Ltd.

Tel: 0086-10-68422061

Fax: 0086-10-68422061

EMAIL: SALES@ELETECHNIC.COM

[HTTP://WWW.ELETECHNIC.COM](http://WWW.ELETECHNIC.COM)

Beijing Eletechnic Ltd. Product Datasheet

<http://www.eletechnic.com>

Page 18